

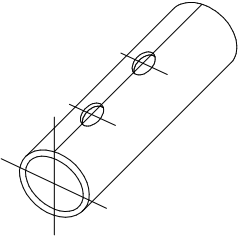

INNOVATIVE PRODUCTS FOR STAGE LIGHTING

FITTING INSTRUCTIONS FOR SMART SOCKETS

<p>1</p>		<p>The Smart Socket is designed for use with 'standard' 48mm aluminium scaffold tube (48.4mm outside diameter, 4.48mm wall thickness). Mark out the positions where the sockets are to be fitted, and drill a 16mm diameter hole through one wall of the tube at each position. Be sure to drill all holes on the centre line of the tube to ensure Smart Sockets fit correctly and end up in a straight line along the bar.</p>
<p>2</p>		<p>Remove any burrs, and firmly press the bush of the Smart Socket Body into the drilled hole. The specially designed tabs, which are part of the bush, will deform to give a tight fit.</p>
<p>3</p>	 <p>Clamp Screws - Pt. No. CS/001/Z (x2)</p>	<p>Fit the Smart Socket Clamp to the Body using the 2 x Clamp Screws supplied. (Robolights Part No. CS/001/Z). Tighten Clamp Screws evenly using a Pozidrive screwdriver until there is an even gap of about 0.5 – 1.0mm between the Clamp and the Body. Do not over tighten – always limit the torque if using powered screwdriver.</p>
<p>4</p>		<p>Draw cables into the bar and up through the Smart Sockets using a draw wire.</p>
<p>5</p>	 <p>Socket Screws - Pt. No. SS/001/B or SS/001/Z (x2)</p>	<p>15A lid versions – Fit 15A socket insert to Smart Socket Lid using 2 x Socket Screws supplied (Robolights Part No. SS/001/B – Black or SS/001/Z – Silver). Connect cables to the 15A socket insert ensuring all terminals are fully tightened – Always limit the torque if using powered screwdriver.</p>
<p>6</p>	 <p>Lid Screws - Pt. No. LS/001/B or LS/001/Z (x2)</p>	<p>Fit the assembled Lid to the Smart Socket Body using the 2 x Lid Screws supplied (Robolights Part No. LS/001/B – Black or LS/001/Z - Silver). Do not over tighten – always limit the torque if using powered screwdriver.</p>

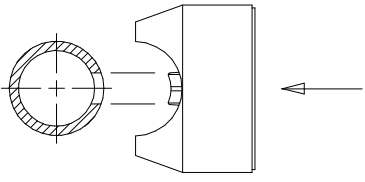
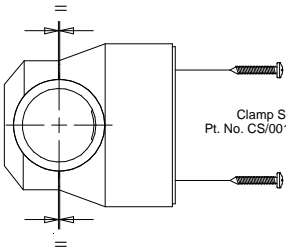
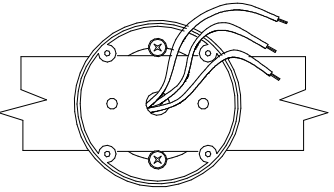
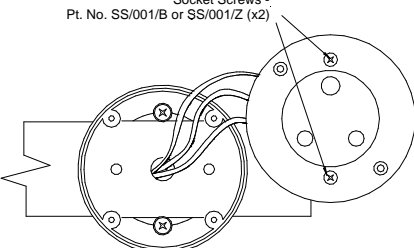
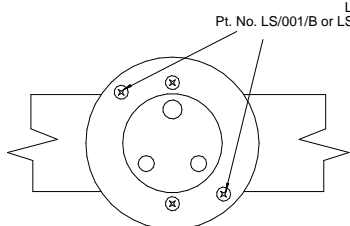

INNOVATIVE PRODUCTS FOR STAGE LIGHTING

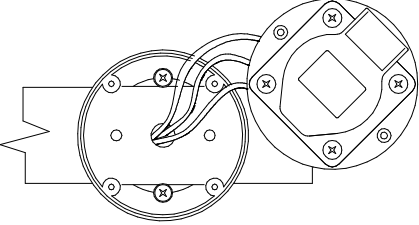
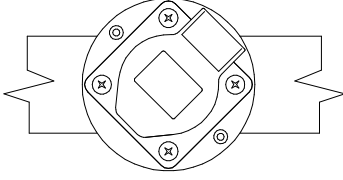
5a		<p>16A lid versions - Fit 16A socket insert to Smart Socket lid using 4 x 16A Socket Screws (Robolights Part No. 16ASS/B – Black or 16ASS/Z – Silver, 4 x M5 Nuts (Robolights Part No. M5N/Z) and 4 x M5 Shake proof washers (Robolights Part No. M5SW/Z) all supplied.</p> <p>Connect cables to the 16A socket insert ensuring all terminals are fully tightened – Always limit the torque if using powered screwdriver.</p>
6a		<p>Fit the assembled Lid to the Smart Socket Body using the 2 x Lid Screws supplied (Robolights Part No. LS/001/B – Black or LS/001/Z - Silver. Do not over tighten – always limit the torque if using powered screwdriver.</p>